



PREMIUM
SolarMaxTM
High Efficiency Solar Hot Water System

*Enjoy
the power of the Sun, and
Save Energy everyday*



How can you get unlimited supply of free hot water, while at the same time reducing your energy consumption? Our answer is simple: the power of the Sun, the only green and free source of energy.

SolarMax Premium

SolarMax Premium is using Blue Titanium TiNOX® collector, specifically designed to provide higher efficiency to our Thermosiphon system.

The higher efficiency Blue Titanium TiNOX® collector with its highly selective surface maximize the absorption of available solar energy, enabling a reduction in the collector size without any compromise on performance.

SolarMax Premium also features our revolutionary multi-flow collector panel which uses a huge 31 tube risers, assembled with ultrasonic welding, to receive the maximum amount of energy from the sun.

SolarMax Premium gives you the guarantee of high performance - Hot water on demand every day!

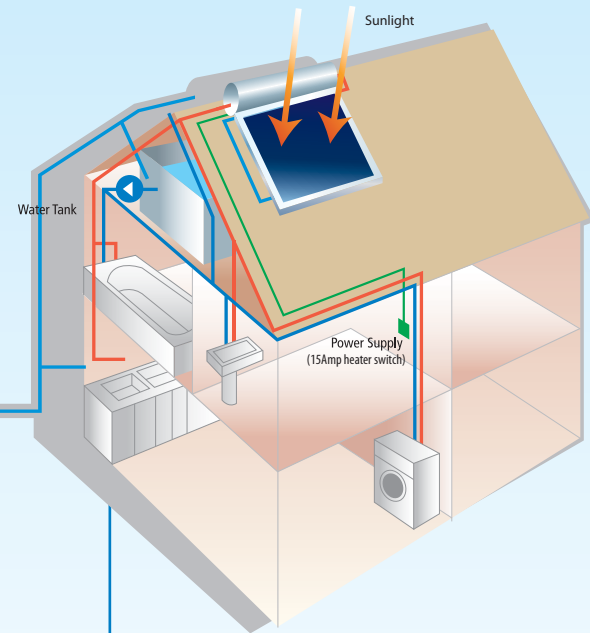

Piping System

Blue Line
Existing cold water piping systems in the house

Red Line
Hot water outlet to be designed part in the house

Unlimited Usage with Centralised Hot Water System

The hot water is available in every corner of your home, with usage not limited to shower only, but also:



Energy Savings

Save electricity and gas usage when boiling water by maximising the solar power.



Safety

Safe where there is no electricity mishaps or gas leak.



Backup Booster

SolarMax has a back-up electric booster for rainy days or during the festive season when you need more hot water than usual. Turn on the booster switch for 30-45minutes and water will be hot ready for use anytime.



Durability

*12 years International warranty.



Environmentally Friendly

Solar energy is clean and totally pollution free.



Trouble Free System

SolarMax is built to last and corrosion resistant. Water is the only moving part. Thus, minimal maintenance is required.

**back-up electric booster with 1 year warranty*

Installation on top of Roof

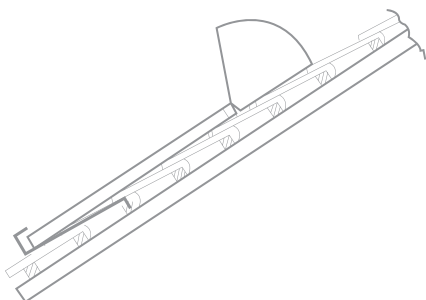

Conceal Tank Installation

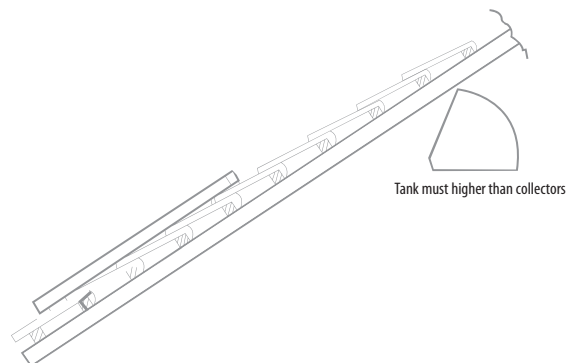

NOTE: SolarMax should be installed along the North-South axis, facing South East to receive maximum solar radiation.

Enhanced Specifications for High Performance

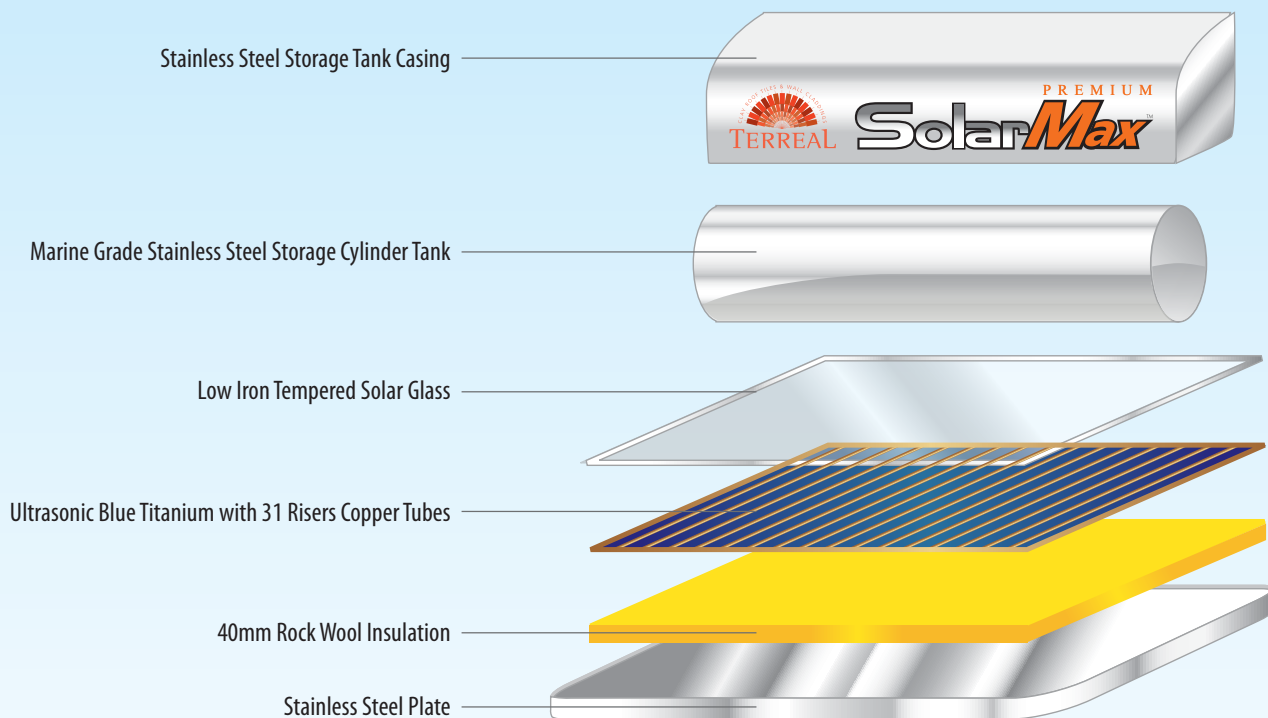

OVERALL DIMENSIONS	MODEL	
	PREMIUM SM 60	PREMIUM SM 300L
Total Capacity	60 gallons 272 liters	66 gallons 300 liters
Overall Dimensions (L x W x H)	2600 x 985 x 460 (mm)	2900 x 985 x 460 (mm)
Overall Weight (Empty)	99kg	104kg
Overall Weight (Full)	372kg	410kg
STORAGE TANK		
Outer Cylinder Case Material	Stainless Steel	
Tank Insulation	High Density Pressure - Injcketed CFC free Polyurethane foam Insulation	
End Cover Material	Stainless Steel	
Tank Cylinder Material	1.5mm AISI 316 Marine Grade Stainless Steel (Japan)	
Normal Working Pressure	500 kpa (5kg/cm ²)	
Relief Valve Setting	700 kpa (7kg/cm ²)	
Overall Test Pressure	1500 kpa (15kg/cm ²)	
Electric Booster Element	3KW / Thermostat	
COLLECTOR		
Design	Ultrasonic Welding	
Plate Material	Copper	
Surface Coating	Blue Titanium	
Absorption Coefficients	95% ± 2%	
Riser Tube Quantity	31	
Glass Material	3.2mm Low Iron Tempered Solar Glass (USA)	
Casing Material	Stainless Steel	
Insulation	Back Panel: 40mm Rock Wool Sides Panel: 10mm Rock Wool	

* Terreal reserves the right to change specifications of the products and their accessories without prior notice.

When you install a **SolarMax Premium** water heater you can be sure you are making the right choice

High Efficiency and Durability for all parts of our System

SolarMax Premium is the only choice when it comes to high efficiency and durability. It combines in a system of Blue Titanium TiNOX® Absorber, Low Iron Tempered Solar Glass and corrosion resistant Stainless Steel for optimum performance.

The new model **SolarMax Premium** system was designed and manufactured in Europe for a range of conditions. Not only it will complement any home's roof and save you immediately on your energy costs, it offers you peace of mind knowing it has been developed to last for years.

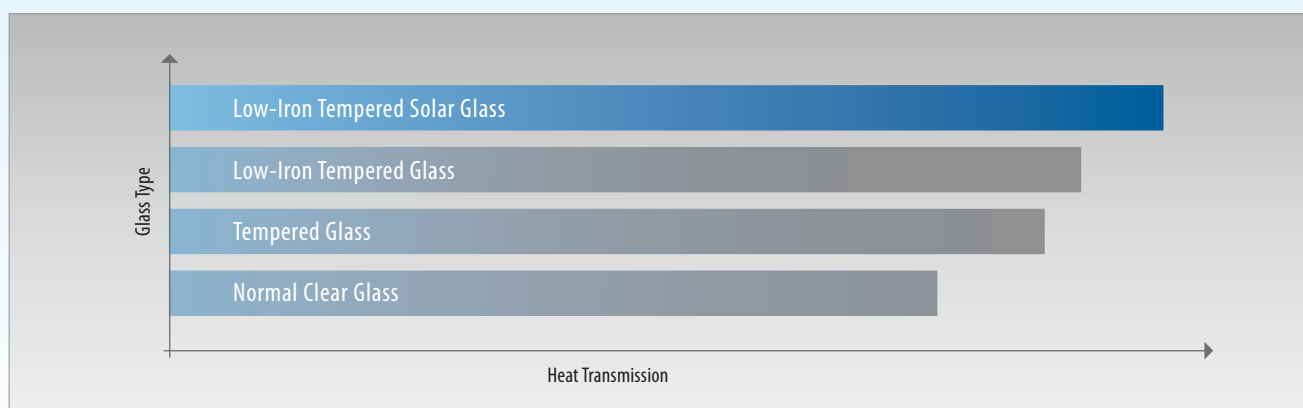

Maximum Heat Radiation Transmission through Solar Glass

The Low Iron Clear Tempered Solar Glass allows higher heat radiation transmission at acute angles of incidence and its textured surface also creates excellent adhesion for solar panels to deliver consistently high and maintenance - free performance. Glass panels are tested at SPF Certification Solar glass (vers 2.1), accordance with European standards for solar photovoltaic panel and solar collector.

Guaranteed Corrossion Resistant with AISI 316 Marine Grade Stainless Steel

The storage cylinder tanks of **SolarMax Premium** roof-mounted solar water heaters are constructed from long life stainless steel, using AISI 316 Marine Grade Stainless Steel. Selected from our experience is the most suitable stainless steel specification with thickness 1.5mm, it acts as a natural barrier to corrossion.

12 years International Warranty

Every **SolarMax Premium** water heater comes with a 12 years international warranty, covering all major components. Back up electric booster is covered with 1 year warranty. So you can relax and enjoy the fact you are getting your hot water free from the sun, knowing that Terreal is behind its product all the way.

Highly Efficient Blue Titanium TiNOX® Collector

The efficiency of any solar system depends on its ability to transform sunlight into heat. High absorption of solar radiation is a basic condition and can be achieved through usage of advanced technological materials. The challenge is to capture the solar-energy inside the collector material. Terreal SolarMax has incorporate its highest efficiency solar heating collector: Blue Titanium TiNOX® absorber, assembled with Ultrasonic welding.

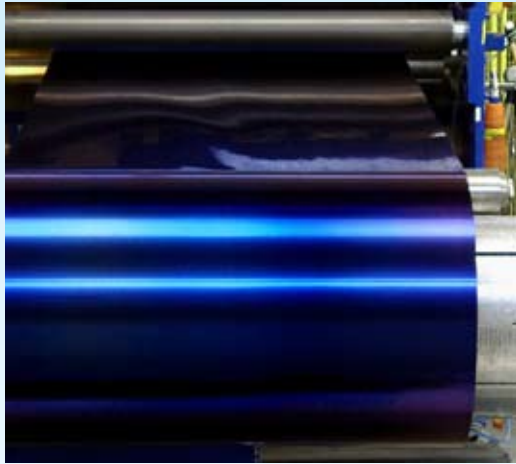

Performance of solar absorbers are considerably increased by the highly selective TiNOX® coating. With conventional black color coated absorber only just under 50% of irradiated solar energy converted into heat. With the highly selective TiNOX® coating a conversion of 90% is achieved - perfectly environmentally friendly!

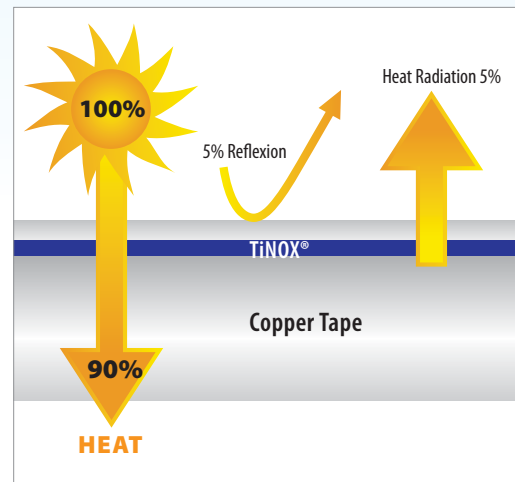
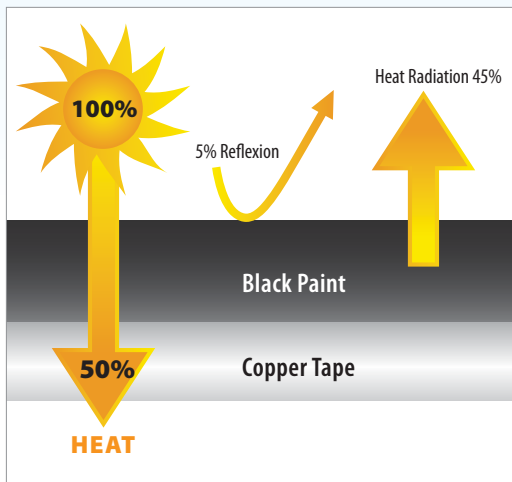

The special TiNOX® coating does not only have a very high absorption. It reduces dramatically the radiation in the infrared spectrum what makes the heat remains inside the absorber (very low emission). As a result collectors equipped with a TiNOX®-coated absorber work far more efficiently, even if the weather is cloudy and still maintains at least 95% of its initial performance after 25 years of use in a flat collector.

All collectors are manufactured in Europe and are tested and certified at Arsenal Research (Austria), Austria Solar, SPF Switzerland and Solar Keymark Germany.



With a Strong International Presence



Terreal is an established world leader with more than 150 years in clay roofing tiles with ambition to open up new creative solutions to tomorrow's landscape builder.

Solar energy, is becoming today's and tomorrow's green energy source. Integration of solar panels with roof tiles has become our focus. Thus, Terreal prides itself in being able to provide both solar photovoltaic systems and solar water heating systems able to satisfy various market.

Terreal offers you a full roofing solution, with high standard of finishing, perfect functionality and full system guarantee.

Terreal SolarMax Premium will save money & energy and is great for the environment.

Call us for free quotation!



Terreal Malaysia Sdn Bhd (202237-P)

No. 25, Jalan TPK 1/5, Taman Perindustrian Kinrara,
Seksyen 1, 47180 Puchong, Selangor Darul Ehsan.

Tel: 603-8075 4010 / 4020 / 4060 Fax: 603-8075 1090

Email: tbf_kl@tm.net.my

www.terreal.com.my

